

three-part design  
highest torque capacity



24-1

## Features

- Highest torque capacity
- Transmissible torque of 18 Nm up to 156 100 Nm
- Tightening of clamping screws with a torque wrench
- Easy disassembly without jacking screws
- Centres the hollow shaft or hub to the shaft
- For hollow shafts or hubs with outer diameters of 14 mm up to 190 mm

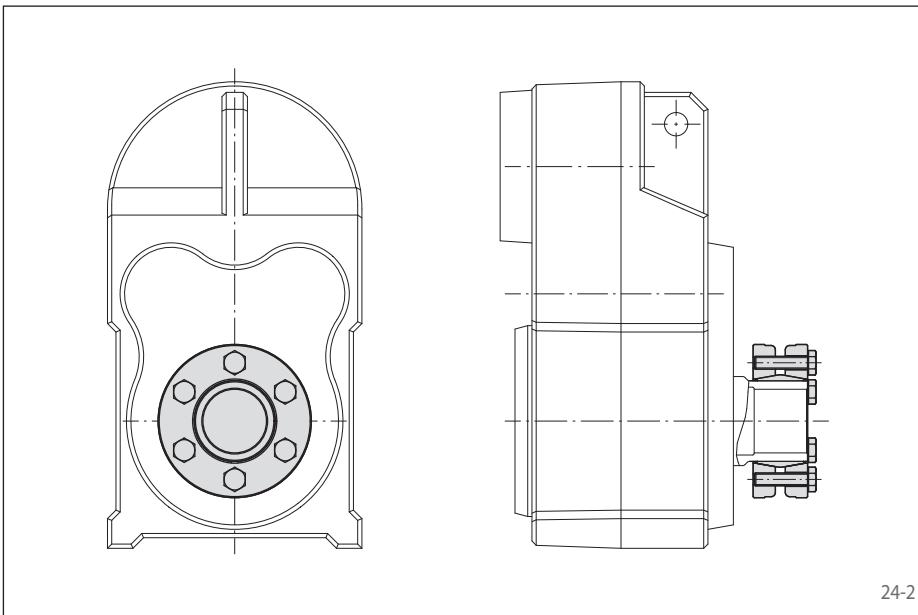

24-2

## Application example

Backlash free connection of a hollow-shaft to a machine shaft on a flat gear box with a Shrink Disc RLK 603 S. The backlash free connection reduces the risk of fretting corrosion. As a result, the connection can be easily disassembled even after long periods of operation.

## Transmissible torques and axial forces

The transmissible torques or axial forces listed on the following page are subject to the following tolerances, surface characteristics and material requirements. Please contact us in the case of deviations.

### Tolerances

d <sub>w</sub>		Hollow shaft bore ISO	Shaft ISO	Joint clearance	
> mm	≤ mm			min. mm	max. mm
10	18	H7	h6	0	0,029
18	30			0	0,034
30	50			0	0,041
50	80			0	0,049
80	120			0	0,057
120	150	H7	g6	0	0,065
150	180			0,014	0,079

Other fits may be selected, provided the joint clearance between the shaft and the hollow shaft remains within the indicated ranges.

### Surfaces

Average surface roughness at the contact surfaces between the shaft and the hollow shaft  $R_z = 10 \dots 25 \mu\text{m}$ .

### Materials

The following apply to the shaft and the hollow shaft:

- Yield strength  $R_e \geq 340 \text{ N/mm}^2$
- E-module ca.  $206 \text{ kN/mm}^2$

## Installation

Please request our installation and operating instructions for Shrink Discs RLK 603 S.

## Simultaneous transmission of torque and axial force

The transmissible torques  $M$  which are shown in the tables apply for axial forces  $F = 0 \text{ kN}$  and conversely, the indicated axial forces  $F$  apply to torques  $M = 0 \text{ Nm}$ . If torque and axial force are to be transmitted simultaneously, the transmissible torque and the transmissible axial force are reduced. Please refer to the technical points on page 31.

## Example for ordering

Shrink Disc RLK 603 S for hollow shaft with an outer diameter  $d = 95 \text{ mm}$ :

- RLK 603 S-95 x 170  
Article number 4200-095301-C00000

three-part design  
highest torque capacity

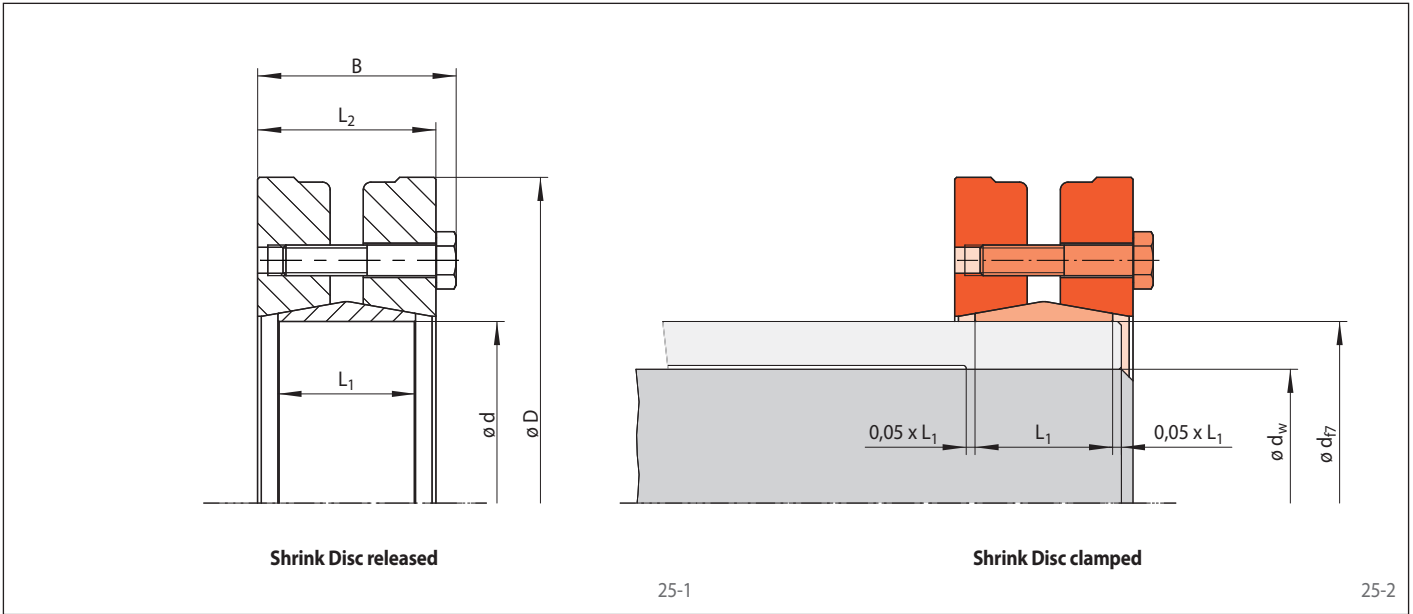

Dimensions						Technical Data							Article number
Size d mm	D mm	B mm	L <sub>1</sub> mm	L <sub>2</sub> mm	d <sub>w</sub> * mm	Transmissible torque or axial force		Clamping screws				Weight kg	
						M Nm	F kN	Tightening torque M <sub>s</sub> Nm	Number	Size	Length mm		
14	37	15	9	12	10	18	4,0	2,4	3	M 4	10	0,1	4200-014301-C00000
					11	37	7,0						
					12	59	10,5						
16	41	18,5	12	15	12	70	15	4	4	M 5	12	0,1	4200-016301-C00000
					13	90	18						
					14	110	20						
18	44	18,5	12	15	14	90	16	4	4	M 5	12	0,2	4200-018301-C00000
					15	100	18						
					16	120	20						
20	46	21	12	17,5	15	110	18	4	5	M 5	16	0,2	4200-020301-C00000
					16	140	22						
					17	160	24						
21	50	22,5	16	19	16	200	31	5	6	M 5	16	0,2	4200-021301-C00000
					17	230	34						
					18	260	37						
24	50	23	16	19	18	240	27	5	6	M 5	16	0,2	4200-024301-C00000
					19	270	28						
					20	310	31						
30	52	27	16	23	24	340	33	5	7	M 5	20	0,2	4200-030301-C00000
					25	470	42						
					26	540	46						
30	60	26	19	22	22	350	32	5	7	M 5	20	0,4	4200-030301-C00001
					24	450	38						
					25	500	40						
36	72	30	22	26	25	600	53	12	6	M 6	25	0,5	4200-036301-C00000
					28	790	58						
					30	800	61						
38	72	30	22	26	25	520	42	12	6	M 6	25	0,6	4200-038301-C00000
					28	730	52						
					30	890	59						
40	72	30	22	26	27	495	46	12	6	M 6	25	0,46	4200-040301-C00000
					30	720	61						
					32	790	70						
44	80	30	22	26	30	840	56	12	7	M 6	25	0,7	4200-044301-C00000
					32	950	59						
					35	1230	70						
48	80	30	22	26	35	1050	59	12	7	M 6	25	0,7	4200-048301-C00000
					38	1300	68						
					40	1500	75						
50	90	32	22	28	35	1350	75	12	9	M 6	25	1,0	4200-050301-C00000
					38	1620	85						
					40	1860	93						
55	100	35	25	31	42	1300	78	12	12	M 6	25	1,1	4200-055301-C00000
					45	1550	87						
					48	1800	96						
62	110	35	25	31	45	2500	111	12	12	M 6	25	1,6	4200-062301-C00000
					50	3250	130						
					55	4050	145						

\*The shaft diameters d<sub>w</sub> listed in the table are selected examples. For other shaft diameters d<sub>w</sub> see the technical specifications on page 31.

three-part design  
highest torque capacity

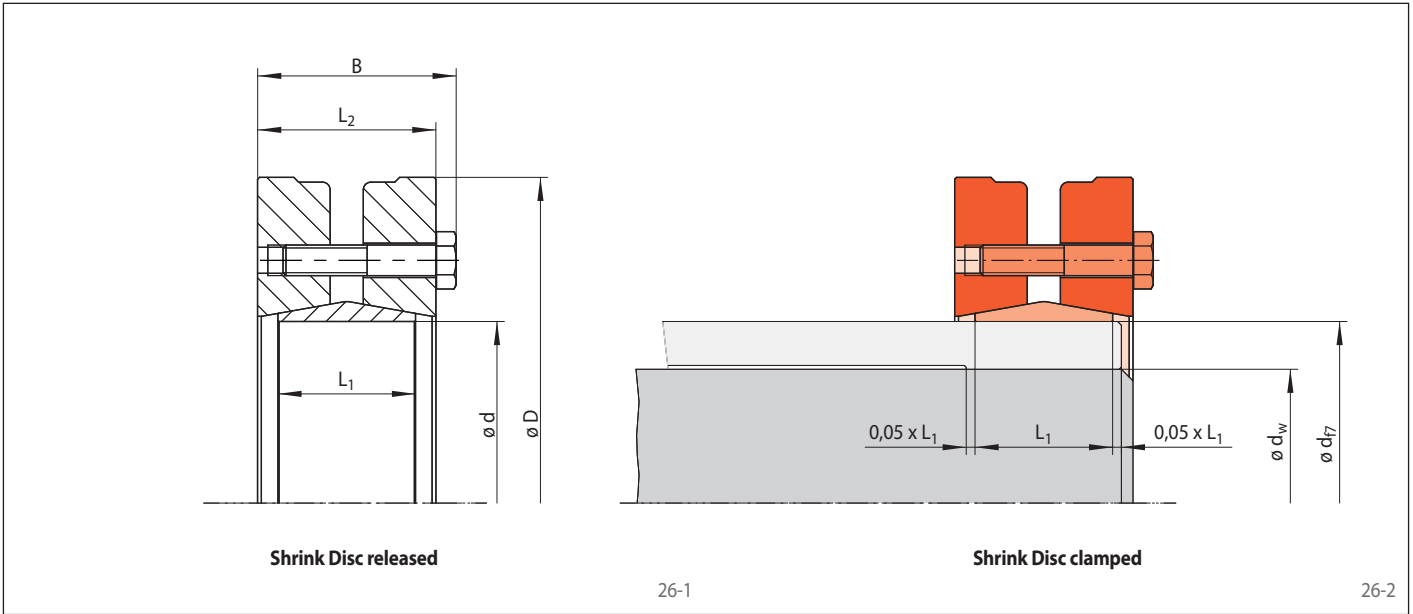

Dimensions						Technical Data							Article number
Size d mm	D mm	B mm	L <sub>1</sub> mm	L <sub>2</sub> mm	d <sub>w</sub> * mm	Transmissible torque or axial force		Clamping screws				Weight kg	
						M Nm	F kN	Tightening torque M <sub>s</sub> Nm	Number	Size	Length mm		
68	115	35,0	25	31	50	2 270	91	12	10	M 6	25	1,4	4200-068301-C00000
					55	3 210	117						
					60	3 610	120						
75	138	38,3	26	33	55	2 650	121	30	7	M 8	30	2,3	4200-075301-C00000
					60	3 300	139						
					65	4 050	158						
80	145	38,3	25	33	60	3 200	126	30	7	M 8	30	2,5	4200-080301-C00000
					65	3 900	143						
					70	4 600	160						
85	155	46,3	33	41	60	5 990	200	30	11	M 8	35	4,2	4200-085301-C00000
					65	7 290	224						
					70	9 130	261						
90	155	44,3	30	39	65	4 800	174	30	10	M 8	35	3,3	4200-090301-C00000
					70	6 050	195						
					75	7 300	215						
95	170	52,3	36	47	65	7 600	235	30	12	M 8	40	5,8	4200-095301-C00000
					70	9 400	270						
					75	11 400	304						
100	170	52,3	36	47	70	6 950	202	30	12	M 8	40	4,4	4200-100301-C00000
					75	7 600	223						
					80	9 100	245						
110	185	62	45	56	75	8 150	259	59	10	M 10	45	6,3	4200-110301-C00000
					80	10 100	285						
					85	12 200	296						
115	185	62	45	56	80	11 800	295	59	10	M 10	45	7,2	4200-115301-C00000
					85	13 600	320						
					90	15 700	349						
120	215	60	44	54	80	13 000	325	59	12	M 10	45	9,0	4200-120301-C00000
					85	15 600	367						
					90	18 300	407						
125	215	60	44	54	85	11 050	300	59	12	M 10	45	8,7	4200-125301-C00000
					90	13 100	327						
					95	15 150	355						
130	215	60	44	54	90	15 700	349	59	12	M 10	45	8,3	4200-130301-C00000
					95	18 300	385						
					100	21 200	424						
135	212	85	63	77	95	25 200	531	100	12	M 12	60	13,0	4200-135301-C00000
					100	29 000	580						
					105	33 100	630						
140	230	68	46	60	95	15 100	365	100	10	M 12	50	10,7	4200-140301-C00001
					100	17 550	395						
					105	20 000	424						
140	304	106	84	96	95	44 300	933	250	12	M 16	70	43,0	4200-140301-C00000
					105	56 700	1 080						
					110	63 600	1 156						
155	265	72	50	64	105	25 500	486	100	12	M 12	70	16,0	4200-155301-C00001
					110	29 200	531						
					115	33 100	576						

\*The shaft diameters d<sub>w</sub> listed in the table are selected examples. For other shaft diameters d<sub>w</sub> see the technical specifications on page 31.

three-part design  
highest torque capacity

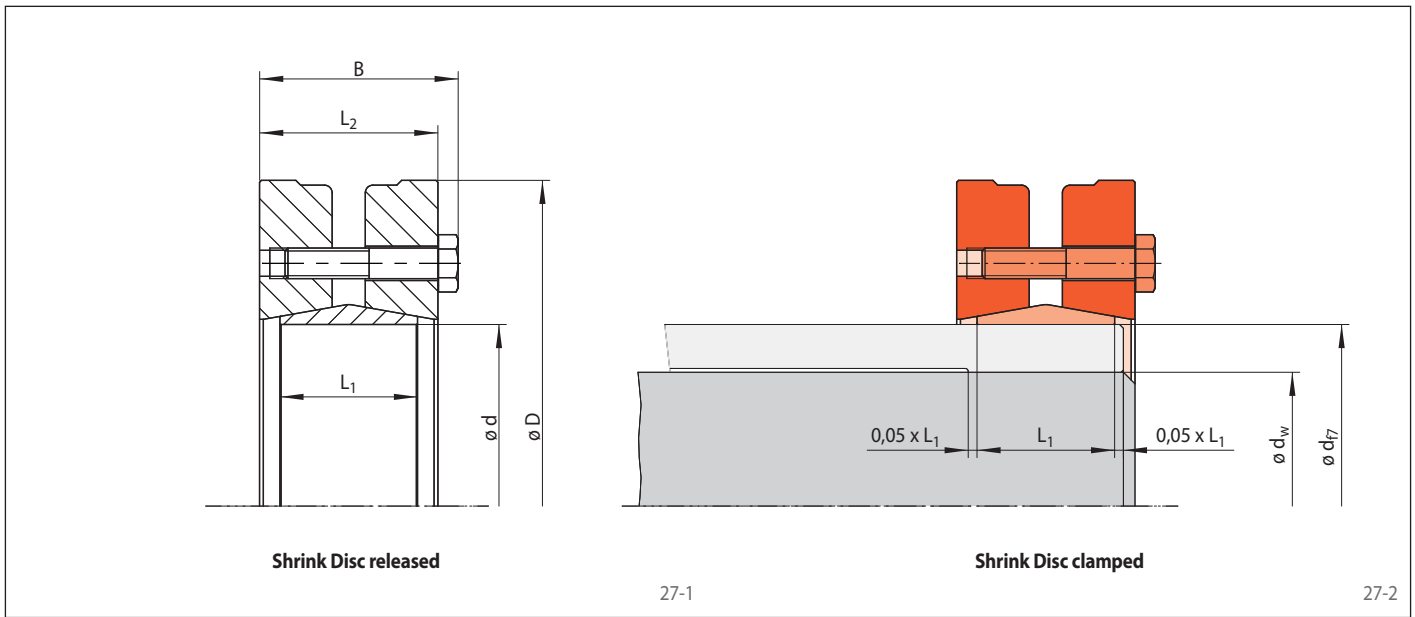

Dimensions						Technical Data							Article number
Size d mm	D mm	B mm	L <sub>1</sub> mm	L <sub>2</sub> mm	d <sub>w</sub> * mm	Transmissible torque or axial force		Clamping screws				Weight kg	
						M Nm	F kN	Tightening torque M <sub>s</sub> Nm	Number	Size	Length mm		
155	263	92	68	84	115	42 700	743	100	15	M 12	70	23,0	4200-155301-C00000
					120	47 700	795						
					125	52 900	846						
160	290	81	56	71	110	33 600	611	250	8	M 16	60	22,4	4200-160301-C00000
					115	37 900	659						
					120	42 400	707						
165	290	81	56	71	115	34 500	600	250	8	M 16	60	21,7	4200-165301-C00000
					120	39 000	650						
					125	43 300	693						
170	290	81	56	71	120	39 100	652	250	8	M 16	60	21,2	4200-170301-C00000
					125	42 700	683						
					130	47 300	728						
175	300	124	98	114	120	86 700	1 387	250	15	M 16	90	42,0	4200-175301-C00000
					125	95 600	1 471						
					130	104 900	1 554						
190	350	130	98	117	135	110 900	1 643	470	12	M 20	90	62,0	4200-190301-C00000
					145	132 600	1 829						
					155	156 100	2 014						

\* The shaft diameters d<sub>w</sub> listed in the table are selected examples. For other shaft diameters d<sub>w</sub> see the technical specifications on page 31.